

# KIT19

## BATTERY TO MIDI FUSE HOLDER CABLE

THE POWER OF  
**REDARC**®

The KIT19 cable is designed to connect REDARC FK23, FK30, FK40 and FK60 fuse kits to a 12 V battery positive (+) terminal. It is suitable for all REDARC BCDC and Manager30 models with charge current ratings up to 50 A.

KIT19 is a 7 AWG (10 mm<sup>2</sup>) cable with a  $\frac{3}{16}$ " (M5) lug on one end and a  $\frac{5}{16}$ " (M8) lug on the other. The approximate length between lug mounts is 5  $\frac{29}{32}$ " (150 mm).

**NOTE:** Some loads can draw very large currents so care must be taken to ensure the total continuous current passed through the cable does not exceed 50 A. For high load current applications a separate dedicated and suitably rated cable should be used.

### KIT19 CONTENTS

- 1 × KIT19 Instruction sheet (this document)
- 1 × Cable with  $\frac{3}{16}$ " (M5) and  $\frac{5}{16}$ " (M8) lugs



## CAUTION

- Cable and fuse sizes are specified by various codes and standards which depend on the type of vehicle the Battery Charger is installed into. Selecting the wrong cable or fuse size could result in harm to the installer or user and/or damage to the Battery Charger or other equipment installed in the system. The installer is responsible for ensuring that the correct cable and fuse sizes are used when installing this Battery Charger.
- NEVER smoke or allow a spark or flame in vicinity of battery or engine. This may cause the battery to explode.

## PERSONAL SAFETY PRECAUTIONS

To assist with the safe operation and use of the Battery Charger when connected to the battery:

- Wear complete eye protection and clothing protection. Avoid touching eyes while working near a battery.
- If battery acid contacts your skin or clothing, remove the affected clothing and wash the affected area of your skin immediately with soap and water. If battery acid enters your eye, immediately flood the eye with running cold water for at least 10 minutes and seek medical assistance immediately.



**Before you begin the installation, check that you have everything you need.**

Additional items are required to complete this installation, and are not included with the kit. The installer must supply all parts, tools, and fasteners that are suitable for the individual installation configuration.

## WIRING THE KIT19

1. Connect the  $\frac{3}{16}$ " (M5) lug on the KIT19 cable to the fuse holder (not included).
2. Connect the  $\frac{5}{16}$ " (M8) lug on the KIT19 cable to the battery positive terminal (bolt not included).
3. Connecting the BCDC to the fuse holder (not included):
  - ▶ If the fuse is on the input side/start battery side of the BCDC, connect the BCDC RED wire to the fuse holder.
  - ▶ If the fuse is on the output side/auxiliary battery side of the BCDC, connect the BCDC output BROWN wire to the fuse holder.
4. Ensure all wiring is secured, well insulated, isolated from heat sources and protected from possible damage.

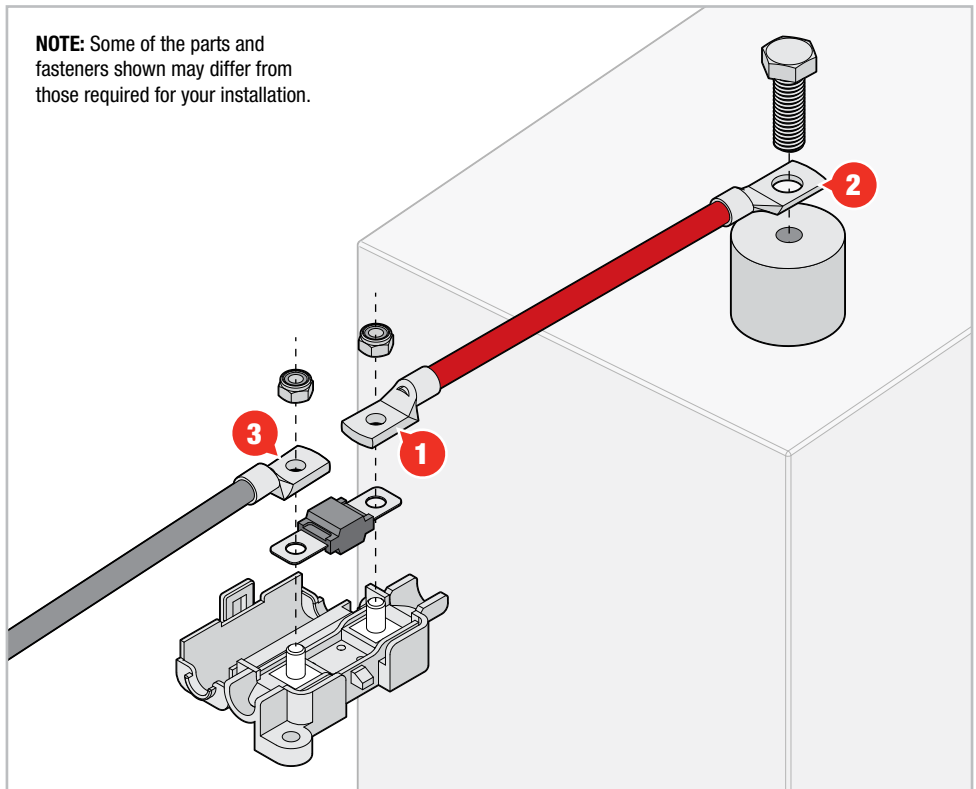

## 2 YEAR LIMITED WARRANTY

The full warranty conditions are available to download and read online.  
Refer to the web address and contact details applicable to your region.

### Australia, New Zealand & Europe

[www.redarc.com.au](http://www.redarc.com.au)

REDARC Electronics Pty Ltd  
23 Brodie Road (North),  
Lonsdale SA 5160

### North America

[redarcelectronics.com](http://redarcelectronics.com)

REDARC Corporation  
c/o Shallco, Inc.  
308 Component Dr.  
Smithfield, NC 27577

## Customer service and warranty contact details:

### Australia (and other Global regions)

[power@redarc.com.au](mailto:power@redarc.com.au)  
[www.redarc.com.au](http://www.redarc.com.au)  
+61 8 8322 4848

### New Zealand

[power@redarcelectronics.co.nz](mailto:power@redarcelectronics.co.nz)  
[www.redarcelectronics.co.nz](http://www.redarcelectronics.co.nz)  
+64 9 222 1024

### North America

[power@redarcelectronics.com](mailto:power@redarcelectronics.com)  
[www.redarcelectronics.com](http://www.redarcelectronics.com)

### United States

+1 (704) 247-5150

### Canada

+1 (604) 260-5512

### Mexico

+52 (558) 526-2898

### UK/Europe

[power@redarcelectronics.eu](mailto:power@redarcelectronics.eu)  
[www.redarcelectronics.eu](http://www.redarcelectronics.eu)  
+44 (0)20 3930 8109

[www.redarcelectronics.com](http://www.redarcelectronics.com)

THE POWER OF  
**REDARC**®