

MNPV2 & 4 Prewired Installation Instructions



MNPV2-MC4 Shown



MNPV4-TYCO Shown

The Pre-wired MNPV combiner is rated for outdoor use. Designed for combining high voltage strings using 10mm x 38mm fuses up to 60 and 80 amps total. The use of touch safe din rail mount fuse holders and fuses allow operation up to 600 Volts. The MNPV2 is rated for up to 60 amps and the MNPV4 is rated for 80 amps.

This Manual covers the following models:

- MNPV4-MC4
- MNPV4-TYCO
- MNPV2-MC4
- MNPV2-TYCO

Application:

- PV combiner employing Tyco or Multi-Contact MC4 bulkhead mount connectors for plug and play installation.

Features:

- Fast, Convenient hook up with industry standard connectors
- All aluminum powder coated housing that won't rust
- Flip up cover that can stay in the open position during installation
- PV Negative bus bar with #6 and 1/0 connections
- Chassis ground bus bar with #6 and 1/0 connections
- Standard din rail holding two or four 15 amp fuses and touch safe fuse holders
- Tin plated copper bus bar that connect PV Plus outputs
- Dead front cover snaps into place after wiring is complete for safety
- Connectors for PV in and PV out on bottom, additional knockouts on bottom and sides
- Top surface is available to bring conduit in from directly above the enclosure

IMPORTANT SAFETY INSTRUCTIONS

SAVE THESE INSTRUCTIONS - These instructions contain important safety and operating instructions for the MidNite Solar Prewired MNPV solar combiner boxes.

If you do not fully understand any of the concepts, terminology, or hazards outlined in these instructions, please refer installation to a qualified dealer, electrician or installer. These instructions are not meant to be a complete explanation of a renewable energy system.

GENERAL PRECAUTIONS

If service or repair should become necessary, contact MidNite Solar Inc. Improper servicing may result in a risk of shock, fire or explosion. To reduce these risks, disconnect all wiring before attempting any maintenance or cleaning. Turning off the inverter will not reduce these risks. Solar modules produce power when exposed to light. When it is not possible to disconnect the power coming from the Photovoltaics by an external means such as a combiner, cover the modules with an opaque material before servicing any connected equipment.

Do not work alone. Someone should be in the range of your voice or close enough to come to your aid when you work with or near electrical equipment.

Remove rings, bracelets, necklaces, watches etc. when working with batteries, photovoltaic modules or other electrical equipment. Power from an illuminated photovoltaic array makes a very effective arc welder with dire consequences if one of the welded pieces is on your person.

Prewired MNPV2 & 4 Installation Instructions (continued)

Installation

Note: The plastic dead front fits very tight. You must first remove the lid in order to remove the deadfront.

To remove the deadfront:

Pry off the lid as shown using something like a screwdriver as a lever. The dead front then lifts out easily.



The installation of a PV combiner is fairly straight forward. Select the location to install your combiner first. Some systems have the PV modules located close to the inverters. If this is the case, you can elect to mount the MNPV inside and run each PV string down to the MNPV inside the building. This is convenient for trouble shooting and upgrading. For longer runs the combiner will be mounted outdoors on the pole for pole mounted PV arrays or similar mounting for rack mounted arrays. The combiner can be mounted in the vertical position or slanted backwards to accommodate up to a 3/12 roof pitch. All unused holes should be blocked using RTV sealant or something similar in order to keep rain and insects out of the enclosure. Care must be taken to insure that no water will get on terminal busbars or fuse holders when mounted less than vertical. Be sure to comply with all local and national code requirements.

Wiring with connectors is pretty much plug and play at least as far as the solar panels are concerned. Simply plug the plus and minus connectors from each string into the plus and minus connectors on the combiner. See the example on the next page. There are various wiring diagrams and system examples available at www.midnitesolar.com click on Documents at the top of the page for links to wiring diagrams in PDF as well as links to AutoCad wiring diagrams and even solid models aimed at aiding the system installer and designer. As such we request that they not be used for any other purpose. Well, maybe puppy training.

The following photos show the connections available on the MNPV2&4. Note that on the MNPV4 the center bottom knock out is sized for a 1 1/4" conduit adapter. The left and right side each have a 1/2" knock out for either wire entry or for MNSPD and other lightning arrestors. Follow directions above (seal with an appropriate goop) when using side knockouts to keep water off internal components. MidNite SPD lightning arrestors do not require a locknut on the outside in order to clear the lid, nor do they require any sealant. Delta arrestors are not UL listed and should not be used as lightning protection.

With either the Solarlok[®] or MC4[®] connectors the positive connection is located near top cover and the negative is located towards the back of the combiner. Use only compatible interconnect cables. The Solarlok[®] connectors may look identical but are keyed for plus and minus.

Caution! Do not disconnect any cables under load. Remove power at the disconnect prior to connecting or disconnecting any cable connections. If necessary, cover the solar panels with opaque material to remove power.

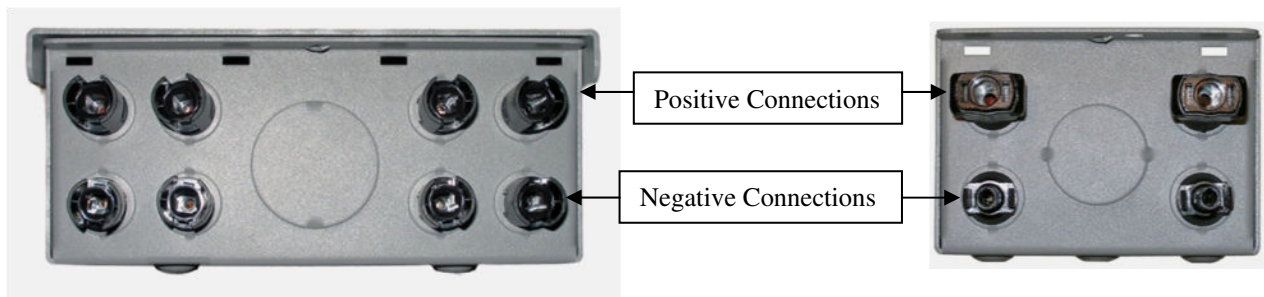

MNPV4-Tyco with Solarlok[®] Connectors

MNPV2-MC4 with MC4[®] Connectors

Prewired MNPV2 & 4 Installation Instructions (continued)

The diagram to the right shows typical connections for the MNPV4 combiner. The MNPV2 is the same except that it combines fewer strings. Note that items inside the dashed lines are external to the combiner.

The solar panel connectors are all factory pre-wired leaving only the combined plus and minus as well as the ground connections to be completed at installation.

Solar panels and wire size: The MNPV2 & 4 are rated for up to 600 VDC. The busbars and output box lug are UL and CSA listed for 90 degree Centigrade.

Torque – Fuseholder	
USM1 Fuse holders	15 in-lbs (1.7Nm)
Torque – Terminal Bus Bar	
10AWG	20 in-lbs (2.3Nm)
8AWG	25 in-lbs (2.8Nm)
6AWG	35 in-lbs (4.0Nm)
4AWG	45 in-lbs (5.1Nm)
2AWG – 1/0	50 in-lbs (5.6Nm)

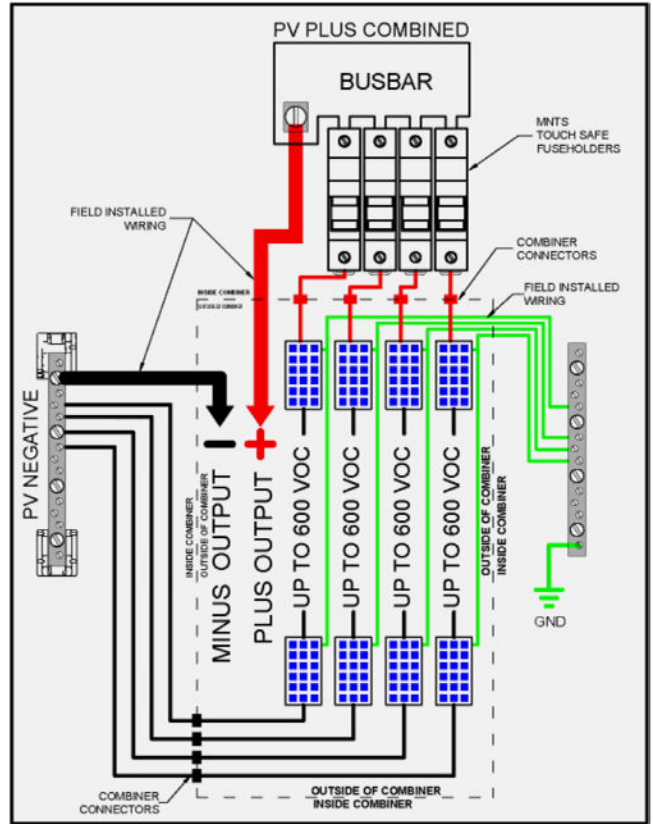

Recommended torque values. These values apply to both bus bars and Plus output box lug.

The fuse holders are factory wired, but use the values above should retightening Be required for any reason. Re-torque fuse holders after one hour.

The MidNite MNPV2 & MNPV4 combiners utilize touch safe fuse holders and fuses rated for up to 600 volts DC. The MNPV2 can accommodate two and the MNPV4 can accommodate four USM1 type fuse holders made by Ferraz Shawmut or other compatible fuse holders.

Fuses are available from 1 to, 30 amps. (80 amps total for MNPV4 & 60 amps total MNPV2)

The combiners come with 15 amp fuses installed.

Do not open the fuseholders under load.

You **WILL** have a fire on your hands!



Left: Combiner installed on A pole mount array.

Right:
 Ferraz Shawmut
 USM1 Touch Safe fuseholder
 Midnite Solar part number - MNTS



Prewired MNPV2 & 4 Installation Instructions (continued)



MNPV2 Factory wiring



MNPV4 Factory wiring

MNPV2 & MNPV4 Specifications

Model Number	MNPV2-TYCO	MNPV2-MC4	MNPV4-TYCO	MNPV4-MC4
Connectors	Solarlok Compatible	MC4 Compatible	Solarlok Compatible	MC4 Compatible
Combines	2 Strings	2 Strings	4 Strings	4 Strings
Factory supplied fuse	(2) 15A	(2) 15A	(4) 15A	(4) 15A
Max VOC	600	600	600	600
Max output amps	60	60	80	80
Input wire range AWG	14-6 AWG	14-6 AWG	14-6 AWG	14-6 AWG
Output wire range AWG	14-1/0 AWG	14-1/0 AWG	14-1/0 AWG	14-1/0 AWG
Mounting angle	90 to 14°	90 to 14°	90 to 14°	90 to 14°
Enclosure type	3R	3R	3R	3R



Midnite Solar 17722 - 67thAve N.E. Arlington, Wa 98223 U.S.A.
360 403-7207 customerservice@midnitesolar.com

Prewired MNPV2 & 4 Installation Instructions (continued)

MidNite Solar surge protective devices have been designed to afford the maximum possible protection for PV combiners, string inverters and AC distribution systems.

Midnite Solar Surge Protection Device.		8-009-1	
Part No.	MNSPD115	MNSPD300	MNSPD600
Nominal Voltage	0 to 100 VAC 0 to 150 VDC	0 to 300 VAC 0 to 385 VDC	0 to 480 VAC 0 to 640 VDC
MCOV VRMS @1mA	180V (162-198)	470V (423-517)	780V (702-858)
ClampV @ 100A Current 8/20µs	295V	775V	1290V
I peak (8/20µs) (Current)	115kA (Full Device) 57.5kA (Each Section)	115kA (Full Device) 57.5kA (Each Section)	115kA (Full Device) 57.5kA (Each Section)
Energy Absorption	1120 J (Full Device) 560 J (Each Section)	3130 J (Full Device) 1560 J (Each Section)	4320 J (Full Device) 2160 J (Each Section)
Suggested Placement	12V,24V,48V DC battery circuits	120/240VAC circuits, offgrid PV combiners and charge controller inputs up to 300VDC,	316V/480VAC circuits Grid tie PV combiners Grid tie inverter input

Diagnosics	Dual Operating LED Indicators. When voltage is present
Operating Temperature Range	-40°c to +85°c
Nominal Discharge Current INA	57.5kA
Thermal Disconnecter Internal	Internal
Response time	<1micro sec.

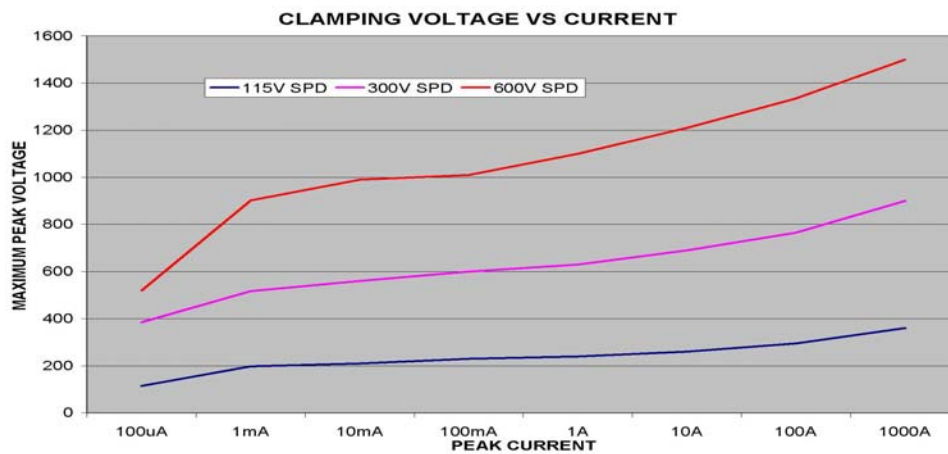

*Installation shown in a MNPV12.
Configured for 2grid tie inverters*

