

RSC-1

RS-232 to EIA-485

Communications Adapter

Installation and Operation Manual



MORNINGSTAR
PROFESSIONAL SERIES

World's Leading Solar Controllers & Inverters

www.morningstarcorp.com

Dimensions

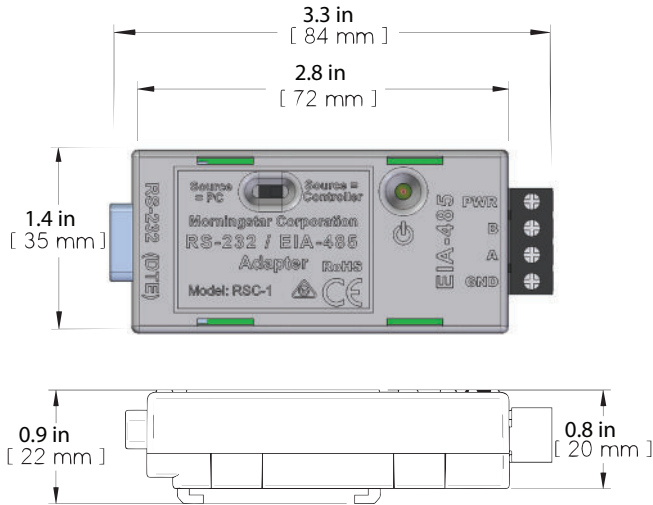

Figure 1. RSC-1 Dimensions.

Technical Specifications

Power Input Voltage	8V - 16V
Self Consumption	8 - 16 mA
Baud Rate	9600 baud
EIA-485 Network Unit Load	1/4
Operating Temperature	-40 C to +60 C
Storage Temperature	-55 C to + 80 C
Humidity	100% N.C.
Enclosure	IP20
Dimensions	72 x 35 x 22 mm
Weight	37 g (1.3 oz)
DIN Rail Compatibility	35 mm (1-3/8")
Certifications	CE, RoHS
Warranty	5 years

Features

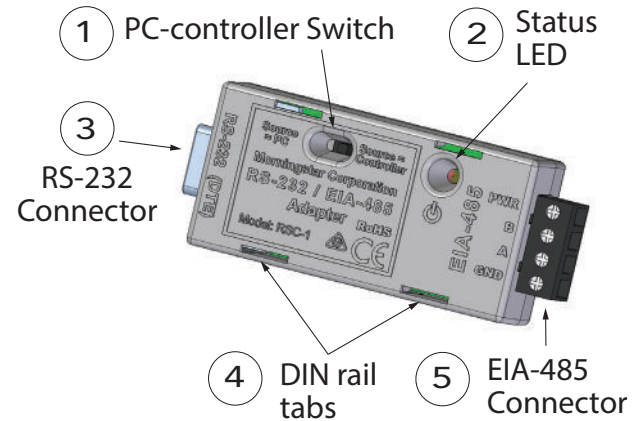

Figure 2. RSC-1 Features.

1 - PC-controller Switch. Sets RS-232 serial input source. Use LEFT-OFF for connecting the RS-232 side to a PC or PC USB to RS-232 cable. Use RIGHT-ON for connecting the RS-232 side to a device with a serial port.

2 - Status LED. Used for monitoring and diagnostics - see pp. 7-8

3 - 9-pin RS-232 connector (male). Use to connect serial cable from PC or system device. An RS-232 ribbon cable with low-profile connectors is included but not shown.

4 - Molded tabs for attachment to 35 mm standard DIN rail

5 - Removable four (4) position EIA-485 terminal

Mounting

The RSC-1 can be mounted on standard 35 mm DIN rail. Four (4) tabs are molded into the bottom of the case. Slide the RSC-1 onto an open end of the DIN rail.

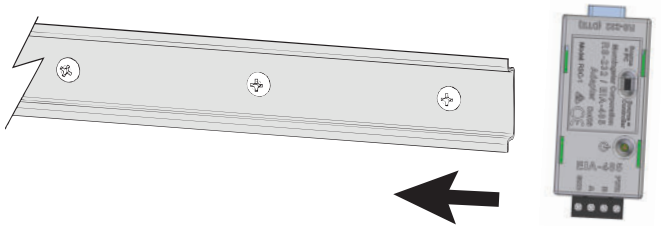

Figure 3. Mounting the RSC-1 to DIN rail

Wiring

Step 1 Daisy-chain EIA-485 Connections

RSC-1 adapters are daisy-chained together as shown in Figure 4. Twisted pair communication cable is highly recommended to maintain data integrity.

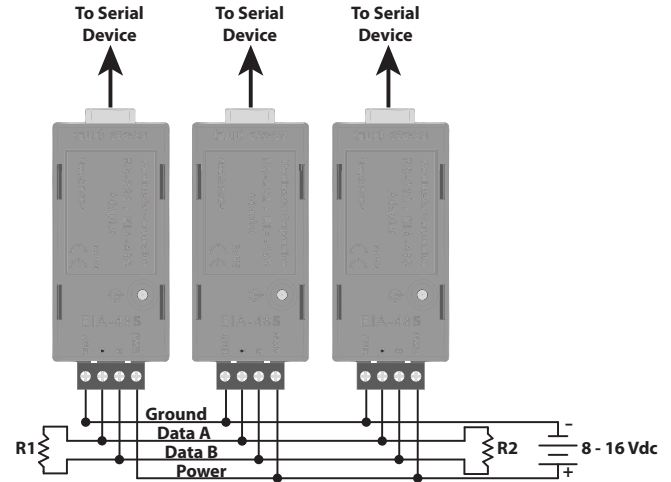

Figure 4. EIA-485 bus wiring

Step 2 - Termination Resistors

Termination resistors (R1 & R2) must be placed on both ends of the data bus as shown in figure 4. If the characteristic impedance of the communication cable is Z_o , then:

$$R1 = R2 = Z_o$$

Check the communication cable specifications for the characteristic impedance.

The typical characteristic impedance of select cables are shown in Table 1, below.

Cable Type	Characteristic Impedance
RS-485 single twisted pair	120 ohm
Category 5 Ethernet	100 ohm

Table 1. Characteristic impedances of select communication cables.

Step 3 - Serial RS-232 Connections

Connect a Morningstar controller, inverter, or accessory to the RS-232 port on the RSC-1 using a straight-through serial cable. A low-profile serial ribbon cable is included with the RSC-1.

Use a *Null Modem* serial crossover cable to connect a PC (or other DCE serial device) to the RSC-1. A Null Modem cable is not included.

Step 4 - EIA-485 Bus Power

The EIA-485 network requires external power. The source voltage must be between 8-16 Vdc. For 12 Volt systems, the network can be powered directly from the system battery. Use a DC-DC converter for 24, 36, and 48 Volt systems.



CAUTION: Tapping power off of individual batteries in a battery bank can cause a voltage imbalance. Damage to the batteries may result. Always use a DC-DC converter if the nominal system voltage is greater than 12 volts.

Network Rules

- Each Morningstar controller, inverter, and accessory on the network must be programmed with a unique Modbus Address. Addresses can be programmed using Morningstar's MSView PC software.
- Do not wire more than 128 RSC-1 adapters on a single EIA-485 network (RSC-1 is 1/4 Unit Load)
-

- Use twisted pair communication cable for the EIA-485 bus.
- Do not run network cables in the same conduit or trough as the system power cables or AC wiring. In general, avoid running network cables in parallel with power cables.
- A MeterBus to Serial Converter (model: MSC) can be used to communicate with Morningstar products that do not have a serial port. See MSC documentation for supported products.

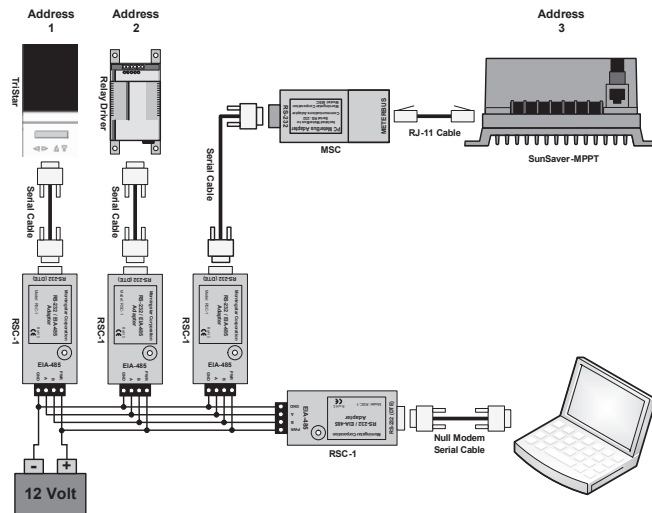

Figure 5. An example EIA-485 network (termination resistors not shown)

Status LED Indications

The Status LED indicates adapter power and network communication. Table 2, below, identifies each of the indication types.

Status LED	Indication	Note
OFF	No bus power or reverse polarity	Check EIA-485 bus power & polarity
Green	Power OK, no data on network	Wiring OK, Ready for transmit / receive
Green / Red Flicker	Data on network	Network OK
Orange	Reversed A & B data lines	Check network wiring

Table 2. LED Indications

Inspection and Maintenance

The following inspections and maintenance tasks are recommended at least two times per year for best performance.

- ✓ Tighten all terminals. Inspect for loose, broken, or corroded connections.
- ✓ Verify that all wire clamps and tie-downs are secure.
- ✓ Check that the adapter is mounted in a clean, protected environment; free of dirt, insects, nests, and corrosion.
- ✓ Verify LED indication is consistent with the present system conditions.

WARRANTY

LIMITED WARRANTY - Morningstar Solar Charge Controllers and Inverters

Integrated Series products, SureSine Family (Gen 2) inverters and other Morningstar Professional Series™ products, except the SureSine™-300 Classic (Gen 1) inverter, are warranted to be free from defects in materials and workmanship for a period of FIVE (5) years from the date of shipment to the original end user. Warranty on replaced units, or field-replaced components, will be limited only to the duration of the original product coverage.

Morningstar Essentials Series™ products, and SureSine™-300 Classic (Gen 1) inverter, are warranted to be free from defects in materials and workmanship for a period of TWO (2) years from the date of shipment to the original end user. Warranty on replaced units, or field-replaced components, will be limited only to the duration of the original product coverage.

Morningstar will, at its option, repair or replace any such defective units.

WARRANTY EXCLUSIONS AND LIMITATIONS:

This warranty does not apply under the following conditions:

- Damage by accident, negligence, abuse or improper use
- PV or load currents exceeding the ratings of the product
- Unauthorized product modification or attempted repair
- Damage occurring during shipment
- Damage resulting from acts of nature such as lightning, weather extremes, or infestation.

THE WARRANTY AND REMEDIES SET FORTH ABOVE ARE EXCLUSIVE AND IN LIEU OF ALL OTHERS, EXPRESS OR IMPLIED. MORNINGSTAR SPECIFICALLY DISCLAIMS ANY AND ALL IMPLIED WARRANTIES, INCLUDING, WITHOUT LIMITATION, WARRANTIES OF MERCHANTABILITY AND

FITNESS FOR A PARTICULAR PURPOSE. No Morningstar distributor, agent or employee is authorized to make any modification or extension to this warranty.

MORNINGSTAR IS NOT RESPONSIBLE FOR INCIDENTAL OR CONSEQUENTIAL DAMAGES OF ANY KIND, INCLUDING BUT NOT LIMITED TO LOST PROFITS, DOWN-TIME, GOODWILL OR DAMAGE TO EQUIPMENT OR PROPERTY.

CLAIM PROCEDURE:

Before requesting warranty service, check the operator’s manual, including any troubleshooting section, to verify product failure. To begin the warranty replacement process, contact your authorized Morningstar distributor or dealer for assistance with troubleshooting and, if necessary, obtaining an RMA number.

An RMA number must be issued by Morningstar prior to return of any unit(s) under this warranty. Required RMA information:

- (A) purchase location - business or company name - and date
- (B) full model and serial numbers (SN is 8-digits on unit bar label)
- (C) failure behavior, including LED indications
- (D) array configuration, panel Pmax, Voc, Vmp, Isc, and nominal battery voltage - these specifications are needed to receive assistance.
- (E) multi-meter available (for field troubleshooting)

After the dealer is contacted, and is not able to assist with warranty claim, contact Morningstar Technical Support at support@morningstarcorp.com. Please provide proof of date and place of purchase, and all details listed in preceding paragraph.

R20-4/23

CERTIFICATIONS



FOR CURRENT DETAILED CERTIFICATION LISTINGS, REFER TO: <https://www.morningstarcorp.com/support/library> Under, “Type”, choose, “Declaration of Conformity (DOC)”, to view a list of product DOCs.

Meterbus™
Morningstar Corporation

MODBUS™ and MODBUS TCP/IP™ are trademarks of Modbus IDA.

©2023 Morningstar Corporation. All rights reserved.