

## Specifications:

	TS-MPPT-30	TS-MPPT-45	TS-MPPT-60/60M	
Battery Voltage	12 Vdc, 24 Vdc, or 48 Vdc			
Maximum PV Open Circuit Voltage	150 Vdc			
Maximum Battery Current	30 A	45 A	60 A	
Battery Operating Voltage	8 to 72 V			
Battery Types Supported	Flooded, Sealed, AGM, Lithium			
Nominal Maximum Output Power <sup>1</sup>	12 Volt	400 Watts	600 Watts	800 Watts
	24 Volt	800 Watts	1,200 Watts	1,600 Watts
	48 Volt	1,600 Watts	2,400 Watts	3,200 Watts
Recommended Maximum PV Array Input Power	12 Volt	550 Watts	825 Watts	1,100 Watts
	24 Volt	825 Watts	1,650 Watts	2,100 Watts
	48 Volt	1,100 Watts	2,100 Watts	4,200 Watts

<sup>1</sup> Higher power arrays can be used without damaging a controller, but exceeding the Recommended Maximum PV Array Input Power may reduce the cost-benefits.

See the Morningstar PV String Calculator at: <https://string-calculator.morningstarcorp.com/>



### IMPORTANT:

Refer to Section 3.0, *Installation*, in the TriStar-MPPT manual, for all details on installation requirements. **System design must comply with any applicable electrical code and regulations.**



### WARNING: Hazardous Voltage

The TriStar charge controller must be installed by a **qualified** technician in accordance with the electrical regulations of the country of installation.



### WARNING: Hazardous Voltage

This unit is not provided with a GFDI device. This charge controller must be used with an external GFDI device as required by the Article 690 of the National Electrical Code for the installation location.

### Accessing the wiring terminals:

#### To Access the Wiring Terminals:

1. Remove the 4 screws and star washers from the faceplate.
2. Lift the faceplate away from the base.

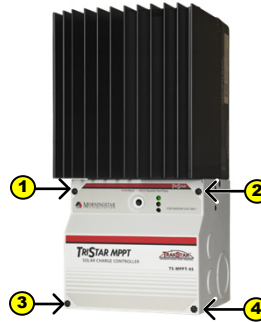

#### To Replace the Faceplate:

1. Align it with the base.
2. Replace the 4 screws and locking washers.
3. Hand tighten, careful not to over-tighten.



# TRISTAR MPPT™

## SOLAR CHARGING SYSTEM CONTROLLER

With TrakStar™ Maximum Power Point Tracking Technology

## Quick Start Guide

### TriStar MPPT Models:

TS-MPPT-30	TS-MPPT-45	TS-MPPT-60	TS-MPPT-60M
------------	------------	------------	-------------

For use with 12 Vdc, 24 Vdc, or 48 Vdc Systems

Scan QR Code to go directly to the TriStar MPPT Installation, Operation and Maintenance Manual, and warranty information online.



**TriStar MPPT Solar Charge Controller**  
(TS-MPPT-30, TS-MPPT-45 & TS-MPPT-60 Models)

**TriStar MPPT Solar Charge Controller**  
TS-MPPT-60M Model  
(includes onboard Meter)



**CAUTION:** This guide must be used with the full product manual that includes important information. Carefully read the TriStar-MPPT product manual for all specifications, safety, regulatory and warranty information, and for all required instructions on installation procedures, configuration, and operation.

## Wire Sizes and Torque Requirements:

Model	MINIMUM WIRE SIZES AND TORQUE REQUIREMENTS						Recommended Circuit Breaker or Fuse Size	
	Stranded Copper Wire Rated for 75°C or 90°C				Ground Terminal	Voltage Sense/RTS Terminals		
	Wire Size in a Raceway, Cable or Earth <sup>1</sup>		Wire Size in Free Air <sup>2</sup>			Minimum		Maximum
	@30°C	@30°C – 45°C	@30°C	@30°C – 45°C				
TriStar-MPPT-30	#8 AWG (8.36 mm <sup>2</sup> )	#8 AWG (8.36 mm <sup>2</sup> )	#10 AWG (5 mm <sup>2</sup> )		#10 AWG (5 mm <sup>2</sup> )	#24 AWG (0.25 mm <sup>2</sup> )	#16 AWG (1.0 mm <sup>2</sup> )	40 Amps
TriStar-MPPT-45	#6 AWG (13.3 mm <sup>2</sup> )	#4 AWG > 40°C (21.1 mm <sup>2</sup> )	#8 AWG (8.36 mm <sup>2</sup> )		#10 AWG (5 mm <sup>2</sup> )	#24 AWG (0.25 mm <sup>2</sup> )	#16 AWG (1.0 mm <sup>2</sup> )	60 Amps
TriStar-MPPT-60/M	#4 AWG (21.1 mm <sup>2</sup> )	#3 AWG > 40°C (26.7 mm <sup>2</sup> )	#6 AWG (13.3 mm <sup>2</sup> )		#8 AWG (8 mm <sup>2</sup> )	#24 AWG (0.25 mm <sup>2</sup> )	#16 AWG (1.0 mm <sup>2</sup> )	75 or 80 Amps
Torque	50 in.-lbs. (5.56 Nm)					3.5 in.-lbs. (0.40 Nm)		
Maximum Distance	See Voltage Drop tables in the Appendix of the TriStar MPPT Installation Manual for maximum distance with < 2% Voltage Drop.				N/A	100 ft (30 m)		

<sup>1</sup> Per NEC 2021 [see NEC Table 310.15(b)(16)], ampacity for not more than three current-carrying conductors in a raceway, cable, or earth (buried)

<sup>2</sup> Per NEC 2021 [see NEC Table 310.15(b)(17)], ampacity for conductors in free air

## Fuses and Circuit Breakers:

- Circuit Breakers or fuses are required in the positive cable for Battery and Solar connections.
- Solar connections require a PV Ground Fault Disconnect.
- A fuse is required in the positive cable for the Voltage Sense connections.
- **Fuse or breaker sizing must be based on required wire ampacity.**
- **If using a fuse, do NOT insert the fuse in the fuse-holder until after all the other connections have been completed.**

## Contact Information:

Technical Support: [morningstarcorp.com/support](http://morningstarcorp.com/support)  
Phone: 1-215-321-4457



## In the Box:



TriStar MPPT Solar Charge Controller

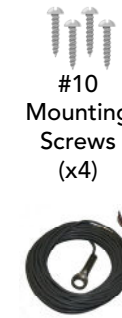

#10 Mounting Screws (x4)  
Remote Temperature Sensor (RTS)

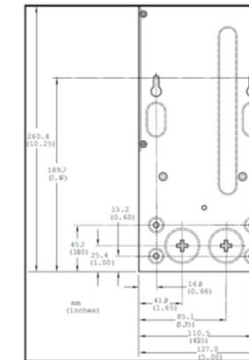

Mounting Template

## Tools Required:

- #2 Philips Screwdriver
- 3/16 (5 mm) & 1/8" (3.8 mm) Flathead Screwdriver
- Drill with a 1/8" (3.8 mm) bit
- Multimeter

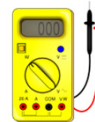

## Optional Accessories



TS-M-2\*

(\*Included with the TS-MPPT-60M model)



TS-RM-2



EIA-485 RS-232 Adapter



MeterHub MeterBus Communication Hub (HUB-1)



Relay Driver (RD-1)



Ethernet MeterBus Converter (EMC-1)

### Minimum Clearance Requirements:

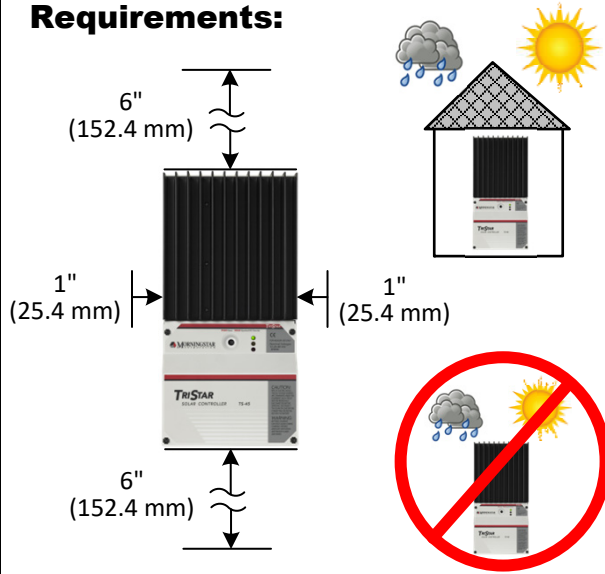

### WARNING: Explosion Hazard

Never install the TriStar in an enclosure with vented/flooded batteries. Battery fumes are flammable and will corrode and destroy the TriStar circuits. Ensure sufficient ventilation.

### CAUTION: Equipment Damage

Do not expose the TriStar CC to weather. Locate in a dry, protected area to prevent equipment damage.

Ensure the minimum clearance requirements are followed to provide adequate ventilation and prevent the unit from overheating.

### Mounting:

#### Step 1: Choose mounting location

- A) Locate the TriStar on a vertical surface that is protected from direct sun, high temperatures, and water.

#### Step 2: Wiring accessibility and air flow clearance

- A) Plan and confirm wire routing-access.
- B) Verify that there is at least 6" of space above and below the unit, and at least 1" (25.4 mm) around the sides.

#### Step 3: Drill holes

- A) Place the TriStar template on the wall where the unit will be mounted.
- B) Mark and drill two (2) 1/8" (3.175 mm) holes in the top end (slot) of each template keyhole.
- C) Drive a #10 screw into each drill hole to 0.25" (or 6.4 mm) from flush with the wall.

#### Step 4: Secure the controller

- A) Place the controller circular keyhole areas over the wall screws, and pull the unit down to lock the screws into the slots.
- B) Use the two remaining screws to fasten the lower part of the unit to the wall.

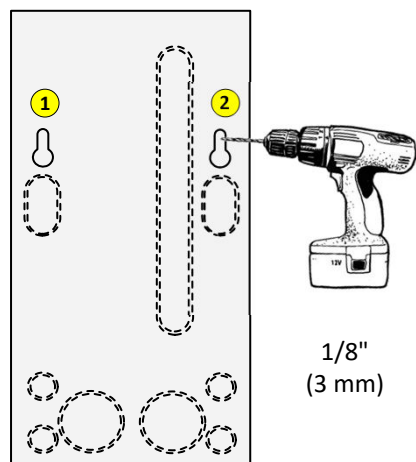
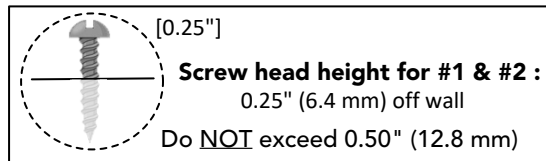

See the Morningstar PV String Calculator at:

<https://www.morningstarcorp.com/support/>

### Photovoltaic (PV) Array

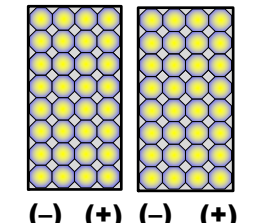
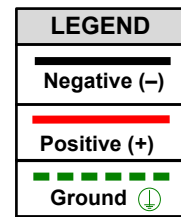

### DIP Switch Block (enlargement)

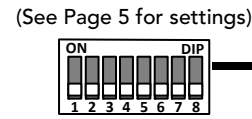

### Solar Disconnect<sup>1</sup>

(PV GFP required per NEC 690)  
(See the Wiring and Torque Table on page 4)

### TriStar MPPT (Solar Controller)

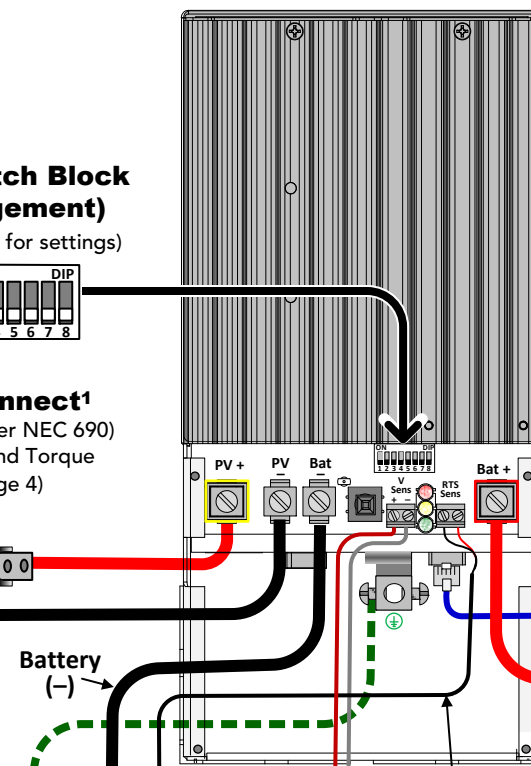

**IMPORTANT:** Array Voltage should **NEVER** exceed the maximum input voltage.

### WARNING: Hazardous Voltage

The PV array can produce open-circuit voltages in excess of 125 Vdc when in sunlight. Verify that the solar input breaker or disconnect has been opened (disconnected) before installing the system wires.

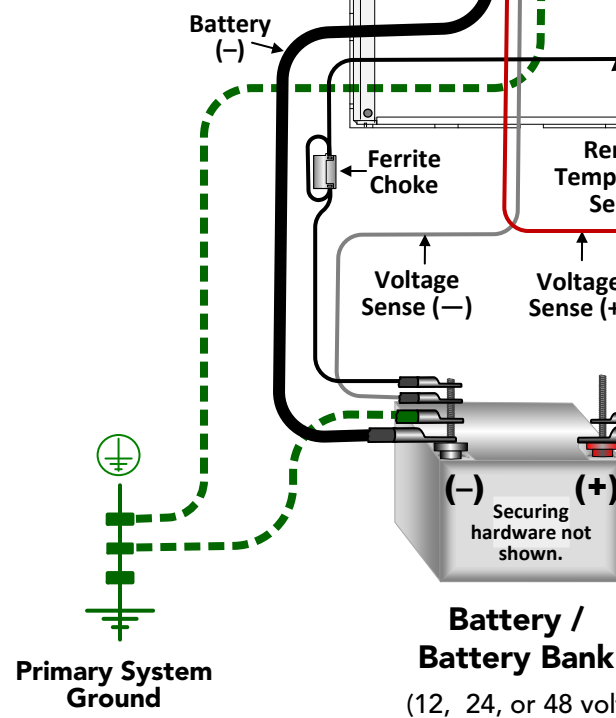

<sup>1</sup>Fuse or breaker sizing must be based on required wire ampacity.

KEEP ALL BREAKERS AND DISCONNECTS OPEN, DISCONNECTED, AND DO NOT INSERT FUSE(S) INTO FUSE-HOLDER(S) UNTIL AFTER ALL OF THE WIRING IS COMPLETED.

### WARNING: Hazardous Voltage

Fuses, circuit breakers, and disconnect switches should never open grounded system conductors. Only GFDI devices are permitted to disconnect grounded conductors.

### WARNING: Hazardous Voltage

Test between all terminals and ground before touching.  
Power or accessory terminals are **NOT** electrically isolated from DC input and may be energized with hazardous voltage.

### IMPORTANT:

Ensure there is **only 1** DC Negative-to-Ground Bond in the entire system.

### CAUTION: Equipment Damage

The TriStar MPPT controller will not provide temperature compensation for the charging parameters without the Remote Temperature Sensor (RTS). The included RTS should always be installed to enable temperature-compensated charging.

**IMPORTANT:** Example only. Actual wiring may vary. **READ** the TriStar MPPT Installation, Operations, and Maintenance Manual for mandatory safety requirements. All configurations must comply with local and national electric codes. Consult your local electric authority to ensure compliance.

### Communications Ports

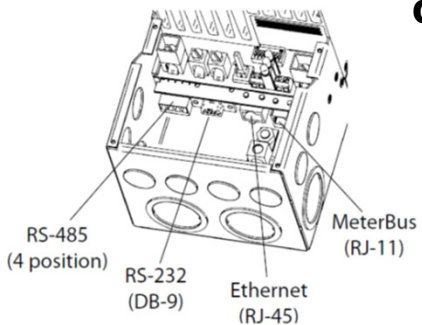

For details on the communications options, see the Installation, Operation and Maintenance Manual.

### Optional Meters

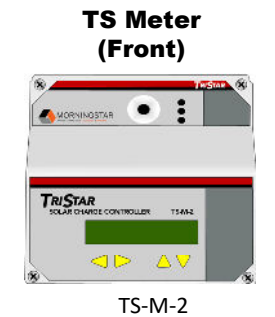
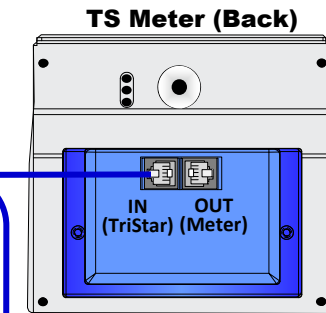

TS-M-2

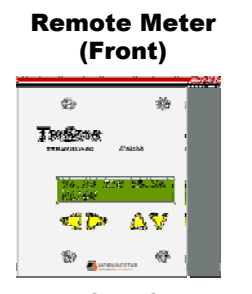
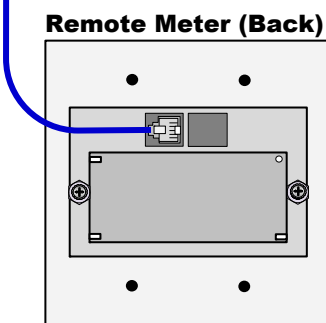

TS-RM-2

### Power UP Sequence:

1. Connect Battery/Battery Bank.
2. Connect Solar.

### Power DOWN Sequence:

1. Disconnect Solar.
2. Disconnect Battery/Battery Bank.



# Operational Settings:

## DIP Switch #1: Battery Charging



Battery Charging



Not used at this time

## DIP Switch #2 & 3: Battery Voltage



Auto Select

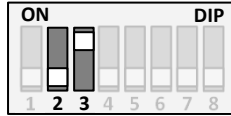

12 Volts



24 Volts



48 Volts

## DIP Switch #4, 5, & 6: Battery Charging Settings

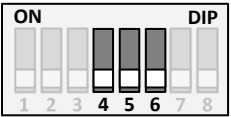

Battery Type = **Gell**  
 Absorption Stage = 14.0 V  
 Float Stage = 13.7 V  
 Equalize Stage = N/A  
 Equalize Interval (Days) = 28

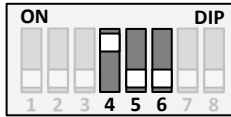

Battery Type = **Flooded**  
 Absorption Stage = 14.6 V  
 Float Stage = 13.5 V  
 Equalize Stage = 15.3 V  
 Equalize Interval (Days) = 28

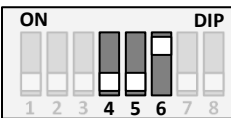

Battery Type = **Sealed**  
 Absorption Stage = 14.15 V  
 Float Stage = 13.7 V  
 Equalize Stage = 14.4 V  
 Equalize Interval (Days) = 28



Battery Type = **Flooded**  
 Absorption Stage = 14.7 V  
 Float Stage = 13.5 V  
 Equalize Stage = 15.4 V  
 Equalize Interval (Days) = 28

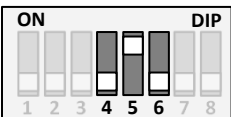

Battery Type = **Sealed**  
 Absorption Stage = 14.30 V  
 Float Stage = 13.7 V  
 Equalize Stage = 14.6 V  
 Equalize Interval (Days) = 28



Battery Type = **L-16**  
 Absorption Stage = 15.47 V  
 Float Stage = 13.4 V  
 Equalize Stage = 16.0 V  
 Equalize Interval (Days) = 14



Battery Type = **AGM/Flooded**  
 Absorption Stage = 14.40 V  
 Float Stage = 13.7 V  
 Equalize Stage = 15.1 V  
 Equalize Interval (Days) = 28



Battery Type = **Custom\***  
 Absorption Stage = Custom V  
 Float Stage = Custom V  
 Equalize Stage = Custom V  
 Equalize Interval (Days) = Custom

(\*Requires Computer Connection. See TriStar MPPT Installation Manual for details.)

## Default Settings

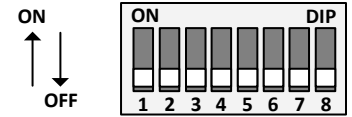

- Battery Charging (1)
- Battery Voltage (2,3)
- Battery Charging Settings (4, 5, 6)
- Battery Equalization Mode (7)
- Ethernet Security (8)

DIP	Function
(1)	Battery Charging Mode
(2,3)	Auto Voltage Select
(4, 5, 6)	Lowest Battery Charging Voltage (14.0 V)
(7)	Manual Equalization
(8)	Ethernet Security Disabled



### CAUTION: EQUIPMENT DAMAGE

The default position for the DIP switches is OFF. Each switch position must be confirmed during installation. **Incorrect settings could cause damage to the battery or other system components.**



### IMPORTANT:

The DIP switches should be changed only when there is no power to the controller. Turn off disconnect switches and remove all power to the controller before changing a DIP switch. A fault will be indicated if a switch is changed while the controller is powered.

## DIP Switch #7: Battery Equalization



Battery Equalization = Manual



Battery Equalization = Auto

## DIP Switch #8: Ethernet Security to Write Commands and Programming



OFF = Disabled



ON = Enabled

This switch enables/disables the ability to send write commands using an Ethernet connection.

- If **Enabled**, settings can NOT be changed and coil commands are disabled.
- If **Disabled**, settings can be changed and coil commands are enabled

## LED DISPLAY AND PUSH-BUTTON FUNCTION:



Push-Button

LEDs

## PUSH-BUTTON FUNCTION:

- **PUSH and RELEASE:** Reset from an error or fault.
- **PUSH and RELEASE:** Reset the battery service indication if this has been activated in custom settings. A new service period will be started, and the flashing LEDs will stop blinking. If the battery service is performed before the LEDs begin blinking, the push-button must be pushed at the time when the LEDs are blinking to reset the service interval and stop the blinking.
- **PUSH AND HOLD 5 SECONDS:** Requests battery equalization manually. The TriStar MPPT 150 V will begin equalization in either the manual or automatic equalization mode. Equalization will begin when there is sufficient solar power to charge the battery up to the equalization voltage. The LEDs will blink the sequence defined below to confirm that an equalize has been requested. The equalization request will automatically stop per the battery type selected. Equalization will only occur if the selected battery type has an equalization stage.
- **PUSH AND HOLD 5 SECONDS:** Stop an equalization that is in progress. This will be effective in either the manual or automatic mode. The equalization will be terminated. The LEDs will blink to confirm the equalize has been cancelled as shown in the table below.

Push-Button Action	SOC LED Indication*
Manual Equalization Started	<b>G / Y / R - G / Y / R - G - G</b>
Stop Equalization	<b>G / Y / R - G / Y / R - R - R</b>

## LED Legend

- **G** = Green LED is illuminated
- **Y-R** = Yellow LED is illuminated, then Red LED is illuminated alone
- **G/Y** = Green and Yellow are both illuminated at the same time
- **Y/R** = Yellow and Red are both illuminated at the same time
- **G/Y - R** = Green & Yellow are both illuminated, then Red is illuminated alone
- **Sequencing** (faults) has the LED pattern repeating until the fault is cleared

## General Transitions:

LED Display Explanation	LED Indication
Controller Startup	<b>G / Y / R</b> (one cycle)
Equalize Start Request	<b>G / Y / R - G / Y / R - G - G</b>
Equalize Cancelled	<b>G / Y / R - G / Y / R - R - R</b>
Battery Service is Required	All 3 LEDs blinking until service is reset*

\*battery service notification is only enabled in custom settings, or when any custom edit is programmed

## Battery Status:

Battery Status	Indication
Equalize Charging Stage	<b>G</b> fast flash – 2.5 times per second
Absorption Charging Stage	<b>G</b> flash – ½ on, ½ second off
Float Charging Stage	<b>G</b> slow flash – 1 second on, 1 second off
13.3 Volts ≤ Vbattery	<b>G</b>
13.0 Volts ≤ Vbattery < 13.3 Volts	<b>G/Y</b>
12.7 Volts ≤ Vbattery < 13.0 Volts	<b>Y</b>
12.0 Volts ≤ Vbattery < 12.7 Volts	<b>Y/R</b>
Vbattery < 12.0 Volts	<b>R</b>

## Battery State-of-Charge (SOC):

State-of-Charge (SOC)	Indication
80% to 95%	<b>G</b>
60% to 80%	<b>G/Y</b>
35% to 60%	<b>Y</b>
0% to 35%	<b>Y/R</b>
Battery is Discharging	<b>R</b>

These State-of-Charge LED displays are for all battery types and system designed.

They are only approximate indications of the battery charge state during charging.

## Faults & Alarms:

Fault / Alarm	Indication
Over-temperature	<b>R-Y Sequencing</b>
High Voltage Disconnect	<b>R-G Sequencing</b>
DIP Switch Fault	<b>R-Y-G Sequencing</b>
Self-Test Faults	<b>R-Y-G Sequencing</b>
Temperature Probe (TRS)	<b>G-R Sequencing, with constant Y</b>
Battery Voltage Sense	<b>G-R Sequencing, with constant Y</b>
Battery Over-Current	<b>R/Y - G Sequencing</b>
Reverse Polarity - Battery	<b>No LEDs are illuminated</b>
Reverse Polarity - Solar	<b>None</b>



For Ethernet LED location and indication descriptions, see the TriStar MPPT Installation, Operation and Maintenance Manual.



For Fault Recovery Instructions, see the TriStar MPPT Installation, Operation and Maintenance Manual.