

BATTLE BORN®

Unstoppable Power Solutions

Product Manual and Installation Guide

30 Amp Hour 12 Volt Lithium Battery

Models: BBBS3012



For Technical Support, please contact: 855.292.2831 | info@battlebornbatteries.com

Document Number: PMI_BBBS3012

Revision: 012

Date: 3/05/2026



Product Name and Model

- Battle Born 30Ah 12V LiFePO4 Battery (Base Series)
 - BBBS3012

Certifications

CE UKCA RoHS IP67



Manufacturer Contact Information – Dragonfly Energy

775.622.3448 | info@dragonflyenergy.com | Dragonflyenergy.com

Customer Support – Battle Born

855.292.2831 | info@battlebornbatteries.com | Battlebornbatteries.com

Information About Your System

As soon as you open your product, record the following information and be sure to keep your proof of purchase.

Serial Number: _____

Purchased From: _____

Purchase Date: _____

This manual provides technical information for the installation, operation, and maintenance of Battle Born® lithium battery systems. Battle Born designs and assembles advanced battery solutions engineered for reliable performance in demanding applications.

The information in this document is intended for qualified installers, system integrators, and end users responsible for configuring and maintaining lithium power systems. Proper installation and system-level protection are required to ensure safe operation and optimal performance.

This manual should be used as a technical reference throughout the product lifecycle, whether for new installations, system expansions, or ongoing maintenance.

For application-specific guidance or technical assistance, contact the Battle Born technical support team.

Table of Contents

Battery Safety	4
Product Overview	7
Battery Operations	11
Battery Storage, Installation, and Maintenance	15
Warranty, Returns & Shipping	20

For additional information and the latest technical literature, please refer to our website: battlebornbatteries.com



Battery Safety



LiFePO₄ batteries are inherently safe; however, like all batteries, energy storage devices, and electrical equipment, they pose potential safety and electrical hazards. Failure to follow these safety instructions could result in electrical shock, injury, or death, as well as damage to the battery, equipment, or property.

WARNING

Failure to follow these safety guidelines can result in property damage, personal injury, or worse. Please read the following material carefully before installation or use:

Do **NOT** rely on the battery's internal BMS as the primary means of overcurrent or surge protection. External fusing or circuit protection sized for the application is required.

Do **NOT** use for cold cranking.

Do **NOT** short battery terminal.

Do **NOT** reverse polarity.

Do **NOT** attempt to disassemble.

Do **NOT** drop or mishandle.

Do **NOT** immerse in water.

Do **NOT** operate with loose connections.

Do **NOT** operate the battery in series or in parallel with any other type of battery.

Do **NOT** operate using cables that cannot accommodate the maximum current that can be delivered by the batteries

Do **NOT** mix battery types or ages.

Do **NOT** expose to fire or high temperatures.

Do **NOT** dispose of in household waste.

Please contact technical support to verify that you are using appropriate cables and contacts.

If the product is damaged upon arrival, please contact the manufacturer for product support.

DISCLAIMERS

- The buyer assumes responsibility for any damages resulting from the misuse of our products.
- Mishandling or misuse of our products will void the warranty.

INSTALLATION

- The battery should be installed as per national and local codes.
- Do **NOT** rely on the battery's internal BMS as the primary means of overcurrent or surge protection. External fusing or circuit protection sized for the application is required.
- The battery should only be installed in locations approved by local building codes.
- Electrical and shock hazards can be minimized by covering the solar array and using insulated tools.
- Do **NOT** short the battery terminals.
- Do **NOT** install the battery if there are any signs of physical damage.
- Do **NOT** install the battery in a location that may be flooded.

OPERATION

- Use only approved battery chargers for charging the battery.
- Do **NOT** disassemble the battery.

EMERGENCY

- Disconnect the battery from the system.
- Wear a respirator, eye protection, and rubber gloves where appropriate.
- Use an ABC type dry chemical fire extinguisher.
- Dispose of as per local regulations.

DISPOSAL

- This product contains lithium-ion batteries and other recyclable materials.
- We strongly encourage customers to recycle unused or retired batteries.
- For guidance on proper recycling methods, please contact us directly.
- Ensure that unused or retired batteries are disposed of responsibly and in compliance with local laws and regulations.



Product Overview

The Battle Born Base Series 12V 30Ah LiFePO₄ battery is engineered to deliver extended runtime and durability. It balances capacity, portability, and rugged design in a compact package. Built with premium quality cylindrical LiFePO₄ cells for consistency, longevity, and safety.

A direct replacement for 12V sealed lead-acid (SLA) batteries, it offers safer operation and more than double the usable capacity in a lighter, longer-lasting design. The internal Battery Management System (BMS) is designed to protect the battery from extreme electrical and thermal conditions.

Encased in a rugged, weather-resistant housing, the Base Series 30Ah is designed to perform in real-world conditions.

Key Features

30Ah / 384Wh Capacity

Extended runtime in a compact size

Premium Cylindrical LiFePO₄ Cells

Safe, stable, and long-lasting

Lightweight & Portable

Easy to transport and install

Advanced Battery Management System (BMS)

Protects the battery from extreme electrical and thermal conditions.

Rugged, Weather-Resistant Build

Dependable in demanding conditions

Certified for Safety

CE and RoHS compliant



BBBS3012 Technical Specifications

Electrical Specifications

Nominal Voltage	12.8V
Rated Capacity	30 Ah (c5 rate)
Minimum Capacity	29 Ah (c5 rate)
Energy	~384 Wh
PbEq (Lead-Acid Equivalent)	~60Ah SLA
Battery Chemistry	Lithium Iron Phosphate (LiFePO ₄)
Battery Cell Form Factor	Cylindrical
AC Internal Resistance	≤ 50 mΩ

Charging Specifications

Recommended Charge Voltage	14.4 ± 0.15 V
Standard Charge Current	6 A
Max Charge Current	15 A
Charge Cut-Off Current	300 - 600 mA
Charge Retention	After charging to full and storing for 28 days under standard test conditions, capacity retention ≥ 80 %.

Discharging Specifications

Standard Discharge Current	15 A
Max Continuous Discharge	30 A
Peak Discharge (≤ 5 seconds)	30 - 60 A
Cut-Off Voltage	10.0V

Charge and discharge current values represent recommended operating limits for normal operation. Internal BMS protection thresholds may occur outside these values and are not intended for routine operation.

*Note: The storage temperature range is -10°F to 140°F (-23°C to 60°C). We recommend bringing the batteries to a 100% charge and then disconnecting them completely for storage. After six months in storage, your batteries will remain 75 to 80% charged.

Storing batteries in subzero weather (-15°F or more) has the potential to crack the ABS plastic and more importantly could cause a faster loss of capacity, in some cases drastically more than the typical 2 to 4% per month loss.

Mechanical Specifications

Dimensions	7.68"L X 5.12"W X 6.14"H (195 x 130 x 156 mm)
Weight	8.6 lb (3.9 kg)
Enclosure Type	Impact-resistant ABS housing
Positive Terminal	M6 Bolt Size (threaded insert)
Negative Terminal	M6 Bolt Size (threaded insert)
Cycle Life	3,000-5,000 Cycles
IP (Ingress Protection) Rating	IP67 – Resistant to dust and light water exposure, such as splashing or rain.

Series/Parallel Compatibility

Supports up to (4) batteries in series and (4) in parallel.

Before connecting in parallel, voltage difference between packs should be ≤ 0.3V. Total system current (after series/parallel connection) must not exceed the rated current of a single battery.

Do not mix new and used batteries or different production batches.

Operating Temperature Range

Charging	32°F to 122°F (0°C to 50°C)
Discharging	-4°F to 140°F (-20°C to 60°C)

Overall Dimensions:

- Length: 7.68 in (195 mm)
- Width: 5.12 in (130 mm)
- Height: 6.14 in (156 mm)

**All dimensions represent the battery case only and do not include terminal height or optional accessories*

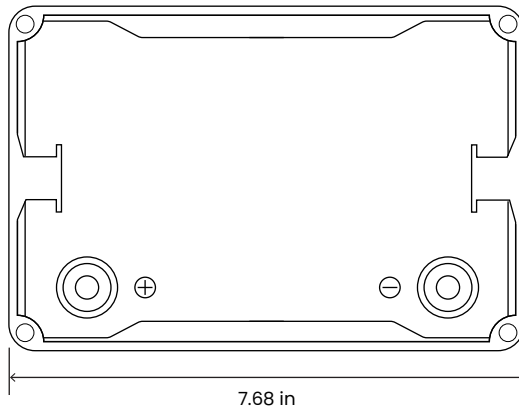
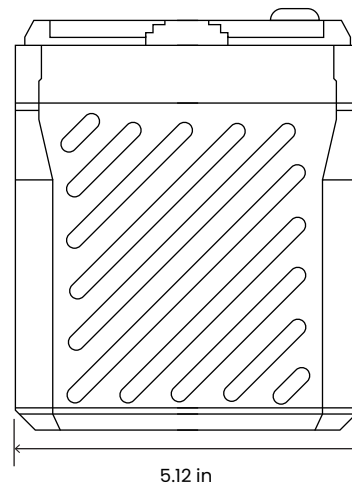
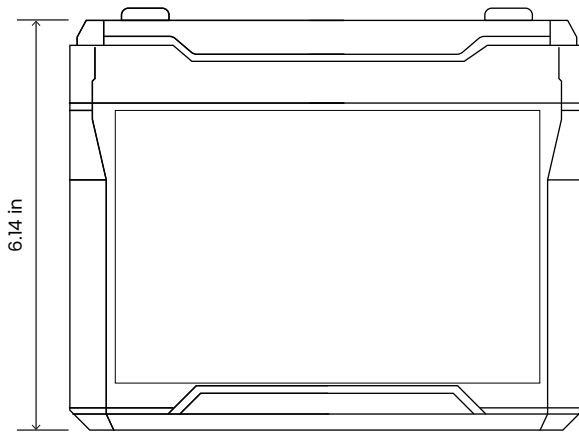



Battery Operations

Charging

When charging, use only a charger that meets the specifications provided in this manual and is designed for lithium-ion or LiFePO₄ battery packs.

Always verify correct polarity before connecting. Do not reverse the positive and negative terminals.

1. Connect the charger's output cable to the battery's charging port first.
2. Then connect the charger's input plug to the wall outlet.
3. Once charging is complete, disconnect the charger from the wall outlet first, then remove the output plug from the battery.

Note: The lithium battery charger is intended for charging only. Do not use it as a power supply or charging station for other devices.

Discharging

When discharging, ensure the battery's positive and negative terminals are properly connected to the matching load.

Verify polarity before connection. Do not reverse polarity.

Charge and Discharge Voltage Characteristics (25 °C, 0.2 c)

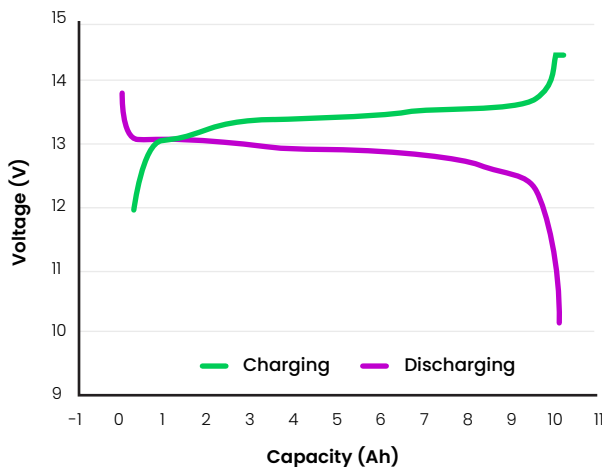

Current Ratings and Protection Behavior

The current ratings listed in this manual represent recommended operating limits for optimal performance and service life. These values are not intended to define instantaneous safety disconnect thresholds.

The internal Battery Management System (BMS) is designed to protect the battery from extreme electrical and thermal conditions. In certain use scenarios, discharge currents above the recommended operating range may occur without an immediate BMS shutdown. In these cases, thermal protection and external system safeguards are relied upon to prevent sustained operation outside recommended conditions.



WARNING

Proper system design, including appropriate wiring, fusing, and load control, is required. The battery must not be relied upon as the sole means of overcurrent protection.

Safety and Handling Precautions

Proper use and maintenance of your Battle Born Batteries® lithium battery system are essential for ensuring long-term performance, safety, and warranty coverage. Follow the guidelines below to prevent damage, overheating, or safety hazards.

Temperature and Environment

- Operate and store the battery within the specified temperature limits.
- Do not expose the battery to open flames, heaters, or corrosive materials.
- If ambient temperature exceeds 113°F (45°C), ensure adequate airflow for ventilation.
- Keep the battery dry and protected from condensation, high humidity, or flooding.

Installation

- Install the battery in compliance with all applicable national and local codes.
- Only install the battery in locations approved by local building codes.
- Avoid installing the battery if there are any signs of physical damage.
- Do not install the battery in any area that may be exposed to standing water or flooding.
- Electrical and shock hazards can be reduced by using insulated tools during installation.

Charging and Operation

- Use only approved lithium battery chargers that meet product specifications.
- Charge and discharge only within rated voltage and current limits.
- Always confirm correct polarity before connecting.
- Never short-circuit the terminals.
- Do not disassemble, modify, or attempt to repair the battery.
- Do not use for cold cranking.

Mechanical and Electrical Integrity

- Do not crush, puncture, drop, or apply excessive pressure to the battery.
- Avoid exposure to strong static discharge or magnetic fields.
- Stop use immediately if the battery emits odor, heat, swelling, or other abnormal behavior.

Emergency Response

- Disconnect the battery from all systems before handling in an emergency.
- Wear appropriate protective equipment such as gloves, eye protection, and a respirator when necessary.
- Use an ABC type dry chemical or lithium-specific fire extinguisher, or dry sand to extinguish flames.

Disposal and End of Life

- Cover battery terminals with non-conductive tape before disposal.
- Recycle unused or retired batteries and packaging materials at an authorized recycling center.
- Ensure disposal complies with all local environmental regulations.



Battery Storage, Installation, and Maintenance

Battery Storage Recommendations

- **Charge Fully:** Bring batteries to 100% state of charge.
- **Disconnect Load:** Remove the negative cable from one battery.
- **Monitor Capacity:** Batteries lose 4-5% capacity per month
 - *Subject to increasing if stored in extreme environmental conditions
 - The integrated Bluetooth dongle consistently draws approximately 10 mA of current.

Make sure to account for this constant power draw when planning your battery storage to ensure optimal performance and longevity.

Storage Guidelines

- Store batteries in a clean, dry, and well-ventilated area.
- Keep away from corrosive materials, heat sources, and direct sunlight.
- Do not store the battery upside down or subject it to vibration or mechanical impact.

Pre-Use Inspection

Before installation or use, carefully inspect the battery for safety and proper function:

- Examine the packaging and case for damage, deformation, or leakage. If found, do not use the battery and contact technical support.
- Ensure terminals are clean, dry, and free of oxidation. Wipe gently with a dry cloth if needed.
- Verify that the polarity and voltage are correct and within the normal range before connection.

Installation Guidelines

- Install the battery in a clean, dry, and ventilated environment, away from moisture and direct sunlight.
- Securely fasten the battery to minimize vibration and movement during operation.
- When connecting terminals, do not overtighten. Excessive torque may damage the terminals.
- After installation, remove any tools, debris, or conductive materials from the surrounding area.
- Confirm correct positive (+) and negative (-) terminal orientation before connection.
- After setup, test the system to ensure the battery and equipment are functioning normally.

Operating Requirements

- Charging current must not exceed the specified maximum. Overcharging may shorten battery life or cause internal damage.
- Discharge current must remain within rated limits. Exceeding it can lead to overheating, internal damage, or safety hazards.
- Recharge promptly after use to prevent deep discharge. Leaving the battery in a low-voltage state for extended periods can cause capacity loss.
- For best performance, discharge to about 10% of rated capacity before recharging and charge to approximately 95% of rated capacity.
 - Shallow discharge cycles help maximize overall cycle life.

Battery Maintenance

- To prevent over-discharge, recharge at least once every two months during storage. Maintain voltage between 13.1–13.6 V.
- If the battery has been unused for an extended period, it may enter a dormant state. Reactivate it with a lithium charger using a low-voltage start or DC power supply.
- Do not clean with organic solvents or chemical agents. Use only a dry cloth if cleaning is required.

- The battery is a consumable product with a limited cycle life. Replace it once capacity no longer meets application requirements.
- Use the original or manufacturer-approved charger. Disconnect promptly once fully charged to avoid overcharge or heat buildup.
- Avoid overcharging and deep discharging, both of which reduce battery lifespan and performance.
- If storing for extended periods, inspect and recharge regularly to prevent capacity degradation.
- **Recycling:** Dispose of spent batteries in accordance with local regulations. Deliver used batteries and packaging materials to an approved recycling facility.

Voltage vs. Capacity (Single Battery)

Battle Born LiFePO₄ batteries, exhibit a characteristic voltage drop during discharge.

The provided voltage vs. capacity charts illustrate the relationship between battery voltage and remaining capacity at different discharge rates. The curves on the chart represent the voltage profile for various discharge currents. It's evident that higher discharge rates result in a steeper voltage decline.

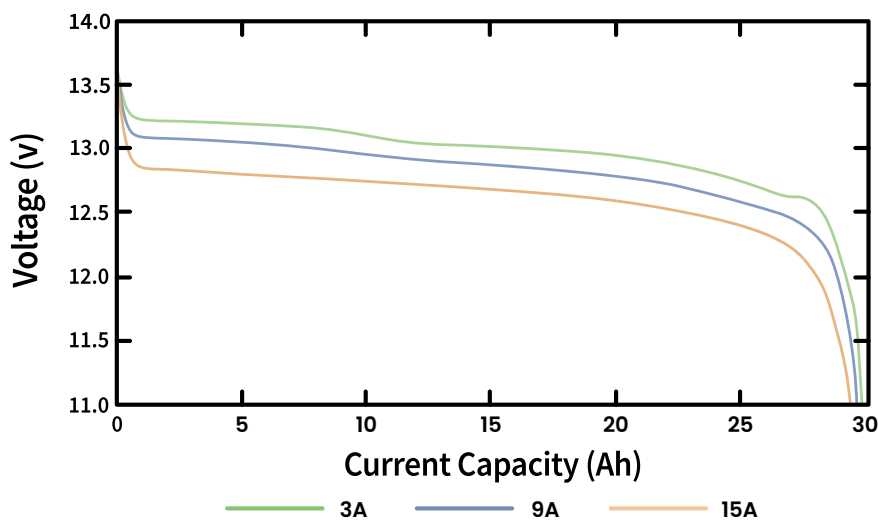

14.4V	100%
13.6V	100%
13.4V	99%
13.3V	90%
13.2V	70%
13.1V	40%
13.0V	30%
12.9V	20%
12.8V	17%
12.5V	14%
12.0V	9%
10.0V	0%

Remaining Capacity

Common Issues and Solutions

Issue	Possible Cause	Recommended Solution
Battery voltage is too low	Voltage < 8.0 - 9.0 V	Measure voltage. If below 10.0 V, isolate the battery and contact technical support. If ≥ 8.0 V, recharge and monitor performance.
Insufficient capacity	Charge imbalance or low SOC	Perform 3–5 full charge/discharge cycles to rebalance capacity.
Voltage instability or abnormal performance	High internal resistance or poor connection	Measure internal resistance. If above specification or unstable, isolate the battery and contact technical support.



Warranty, Returns & Shipping

Limited Warranty

Please find Limited Warranty information online at www.battlebornbatteries.com/limited-warranty/ or via phone at (855) 292-2831.

Return Policy

You have 30 calendar days to return an item from the invoice date. To be eligible for a return, your item must be in the same condition that you received it in. You must have the receipt or proof of purchase. You are responsible for any shipping costs to return items to Dragonfly Energy Corp. If an item is new, unused, and in the original packaging, we are happy to accept a return up to 30 days from the original invoice date with no restocking fee. The item must be returned with its original packaging. Original packaging must be in the same condition as it was received, otherwise you may be responsible for a restocking fee. If the item has been installed, used, or no longer has the original packaging, we will assess a restocking fee that will be shared when the return merchandise authorization (RMA) is issued. Items 60 days past the original invoice will be reviewed at Battle Born's discretion.

Returns will not be accepted without an RMA number, which can be obtained by filling out the return form at <https://battlebornbatteries.com/returns/>.

To avoid being charged restocking fees, review the full return/refund policy at www.battlebornbatteries.com/terms-conditions/#returns.

Refund Policy

You have 30 calendar days to return an item from the invoice date. Once we receive your item, we will inspect it and notify you that we have received your returned item. We will immediately notify you of the status of your refund after inspecting the item. If your return is approved, we will initiate a refund to your credit card (or original method of payment). You will receive the credit within a certain amount of days, depending on your card issuer's policies. No refund is guaranteed after the initial 30 days has passed or if the item has been used.

Shipping

You will be responsible for paying for your own shipping costs for returning your item. Shipping costs are nonrefundable. If you receive a refund, the cost of return shipping may be deducted from your refund.

If you have any questions, please contact us by calling 855-292-2831 or email us at info@battlebornbatteries.com.

BATTLE BORN®

Unstoppable Power Solutions

Notice: Product improvements and enhancements are continuous; therefore, the specifications and information contained in this document may change without notice. Dragonfly Energy Corp. shall not be liable for errors contained herein or for incidental or consequential damages in connection with the furnishing, performance, or use of this material. No part of this document may be photocopied, reproduced, or translated to another language without the prior written consent of Dragonfly Energy Corp.

Copyright © 2026, Dragonfly Energy Corp., all rights reserved. Battle Born Batteries® and Battle Born® are registered trademarks of Dragonfly Energy Corp. All other trademarks, trade names, service marks, and logos referenced herein belong to their respective owners.