

m-Series Single Circuit ON/OFF Battery Switch

6006 / 6006200

Features

- Switches a single battery to a single load group
- Tin-plated copper studs for maximum conductivity and corrosion resistance
- Studs accept 3/8" (M10) ring terminals
- One-piece terminal stud design never loosens over time
- Isolating cover with three snap-off side pieces protects rear contacts and allows wire access in any direction

Specifications

Cranking Rating: 30 sec.	900A DC
Intermittent Rating: 5 min. (UL 1107)	500A DC
Continuous Rating:	300A DC
Terminal Stud, Tin-Plated Copper	3/8"-16 (M10)
Torque	120 in-lb (13.56 N·m)
Cable Size to Meet Ratings*	4/0 AWG (120 mm ²)
Maximum Voltage Rating	48 Volts DC
Ignition Protected	
CE marked	

Agency Specifications

- Meets all American Boat and Yacht Council (ABYC) requirements for battery switches
- UL Listed - UL 1107 for electric power switches
- Meets UL 1500 and SAE J1171 external ignition protection requirements

Guarantee

Any Blue Sea Systems product with which a customer is not satisfied may be returned for a refund or replacement at any time.

* Reducing cable sizes will reduce current ratings

Blue Sea Systems, Inc.
4600 Ryzex Way
Bellingham, WA 98226 USA
p 360.738.8230
blueseasystems.com

Caution

- **Disconnect positive battery terminal before installing.**
- Débranchez la cosse positive de la batterie avant de l'installer.
- Desconecte el terminal positivo de la batería antes de la instalación.
- Prima di eseguire l'installazione, disconnettere il terminale positivo della batteria.
- **Consult marine electrical professional for proper wiring application.**
- Consultez un professionnel de l'électricité marine pour installer le câblage correctement.
- Consulte a un electricista marino profesional para la aplicación de alambrado apropiada.
- Per assicurarsi che i cavi siano correttamente collegati, rivolgersi ad un elettricista specializzato in motori marini.

Installation

- **Refer to the latest edition of NFPA 302 and/or ABYC E11 Standard for installation information.**
- **Attach one 4/0 AWG cable per terminal to meet ratings.**
- Raccordez un câble 120 mm² par cosse pour respecter les spécifications.
- Sujete un cable 120 mm² por terminal de acuerdo a la clasificación.
- Attaccare un cavo 120 mm² per conformarsi alle tarature.
- **Battery cable terminals must be attached under nut and lock washer. Torque 120 in-lb (13.56 N·m).**
- Les cosses des câbles de batterie doivent être fixées sous la rondelle de sûreté et l'écrou – couple de serrage de 13,56 N·m (120 lb-po).
- Los terminales de los cables de batería deberán ser sujetados debajo de la tuerca y la arandela. Apriételes a una torsión de 13,56 N·m (120 lbs-pul).
- I terminali del cavo della batteria vanno attaccati con un dado e una rondella elastica: coppia di 13,56 N·m (120 lbs-in).

Operation

- **Turn all appliances off before turning the battery switch to OFF.**
- Éteignez tous les appareils électriques avant de mettre l'interrupteur de batterie sur ARRÊT.
- Apague todos los artefactos antes de girar el interruptor de batería a APAGADO (OFF).
- Spegnere tutte le apparecchiature prima di muovere l'interruttore della batteria su OFF (spento).
- **Do not switch to OFF while engine is running.**
- Ne le mettez pas sur ARRÊT alors que le moteur tourne.
- No coloque el interruptor en APAGADO (OFF) mientras que el motor esté funcionando.
- Non muovere l'interruttore su OFF (spento) quando il motore è in moto.

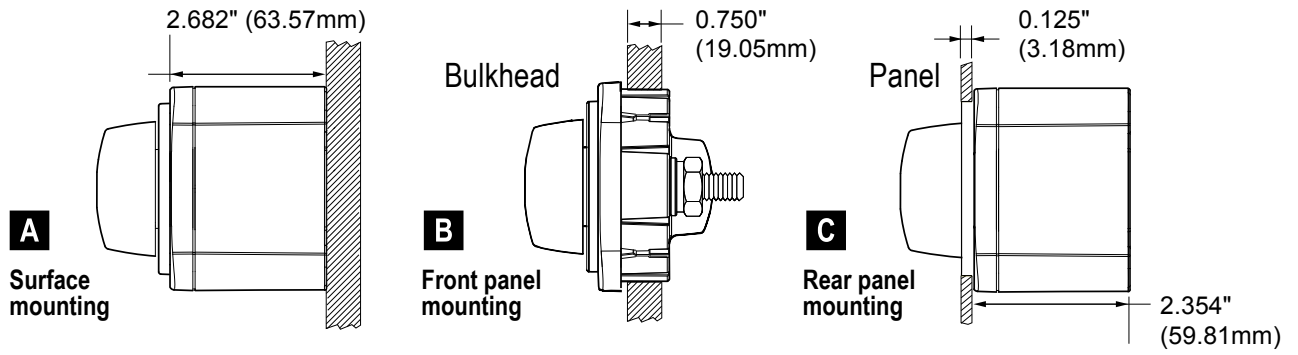

Switch Mounting Options

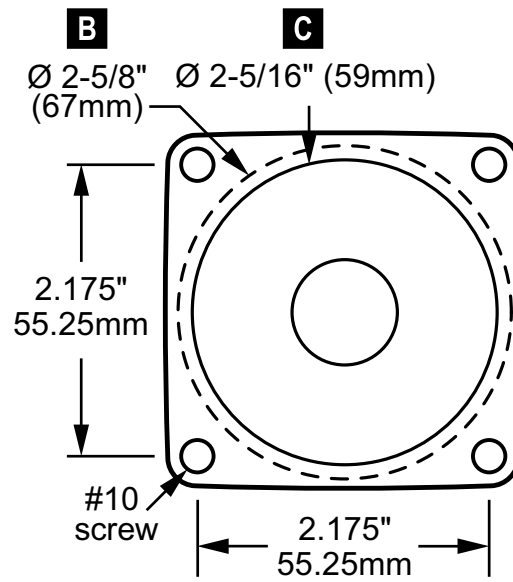

M-Series Battery Switch Dimensions

